



**YANMAR**

**WHEEL LOADER**

**V3-6**

**V4-6**



**YANMAR · YOUR BEST PARTNER FOR BUILDING THE FUTURE**

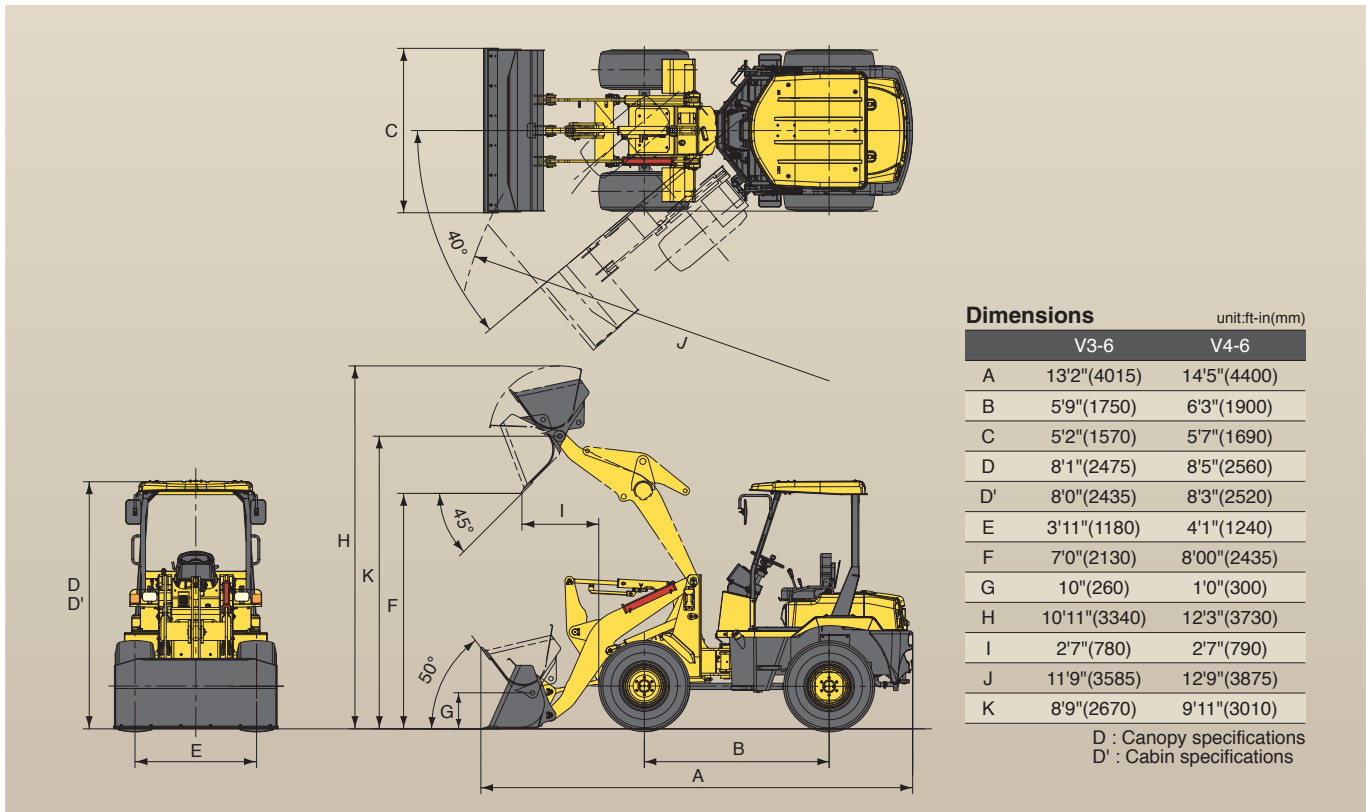

		Dimensions	
		unit:ft-in(mm)	
		V3-6	V4-6
A		13'2"(4015)	14'5"(4400)
B		5'9"(1750)	6'3"(1900)
C		5'2"(1570)	5'7"(1690)
D		8'1"(2475)	8'5"(2560)
D'		8'0"(2435)	8'3"(2520)
E		3'11"(1180)	4'1"(1240)
F		7'0"(2130)	8'00"(2435)
G		10"(260)	1'0"(300)
H		10'11"(3340)	12'3"(3730)
I		2'7"(780)	2'7"(790)
J		11'9"(3585)	12'9"(3875)
K		8'9"(2670)	9'11"(3010)

D : Canopy specifications  
D' : Cabin specifications

### Specifications

MODEL		V3-6	V4-6	
ENGINE	Type	water-cooled 3-cyl. diesel		
	Model	YANMAR 3TNV88-BNKAH		
	Output	HP(kW)/min <sup>-1</sup> 30.3(22.6) /2500		
PERFORMANCE	Displacement	cu.in(ft) 100.2 (1.642)		
	Std. bucket capacity	cu.yd(m <sup>3</sup> ) 0.52 (0.4)		
	Operating load	lb(kN) 1962 (8.7)		
	Lifting capacity at low end	lb(kN) 5760 (25.6)		
	Tipping load	straight	lb(kN) 4785 (21.3)	
		full turn	lb(kN) 3924 (17.4)	
	Breakout force	lb(kN) 5400 (24.0)		
	Dumping clearance	ft-in(mm) 7'0" (2130)		
	Traveling speed	mph(km/h) 11.8 (19.0)		
	Oscillation angle	degree ±8		
PTO	Front Hyd.PTO	PSI(kPa) 3000(20590)		
		GPM(L/min) 10.7 (40.5)		
STEERING	Type	Center-pivot frame articulation with full hyd. power		
	Articulate angle	degree 40		
TRANSMISSION	Type	Automatic hydrostatic		
DRIVES	Type	4-wheel drive		
WHEELS	Type	12.5/70-16-6PR	15.5/60-18-8PR	
BRAKES	Type	Fully enclosed, mechanical, wet, multiple disc		
OPERATING WEIGHT	Canopy	lb(kg) 6801 (3085)		
	Cabin	lb(kg) 7264 (3295)		
TRANSPORT DIMENSIONS	L×W×H	ft-in 13'2"×5'2"×8'1"		
		mm 4015×1570×2475		

Note : All information presented in this Brochure is subject to change without notice.

### YANMAR AMERICA CORP.

#### CONSTRUCTION EQUIPMENT DIV.

101 International Parkway, Adairsville, GA 30103, U.S.A.  
TEL:770-877-7570 FAX:770-877-7572  
http://www.yanmar.com